

ART 369

PN32 Bronze 'Y' Type Strainer with Tapping Points

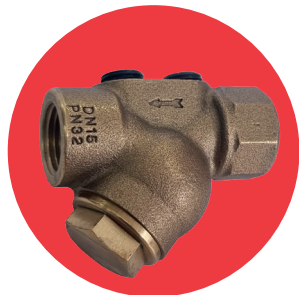

Features

- Screwed BSP Taper (ISO 7/1)
- NPT (ANSI B1.20.1) version available on request
- Can be fitted with flow verification test points
- Suitable for water, steam, and oil
- Screen: Woven wire 20 mesh (0.85mm aperture - 51% open area)
- Test points (ART 299) to be purchased separately

Technical data

Max pressure: 32 Bar

Max pressure (Steam): 13.8 Bar @ 197°C

Working temp:

-10°C to +200°C (with plugs)

-10°C to +135°C (with ART 299)

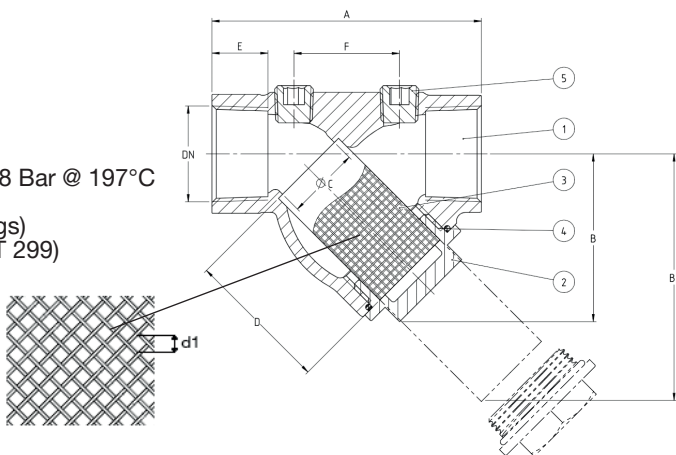

DN	1/2"	3/4"	1"	1.1/4"	1.1/2"	2"
A	67	74	92	106	114	147
B	42	47	57	66	78	100
B'	56	70	84	99	116	150
C	15	21	25	25	37	50
D	32	41	49	58	65	83
E	15	16	19	21	21	26
F	19	24	36	40	44	57
D1	0.85	0.85	0.85	0.85	0.85	0.85
Kv	9.0	18.0	24.0	25.8	55.5	90.0
Kgs	0.3	0.4	0.7	1.0	1.3	2.3

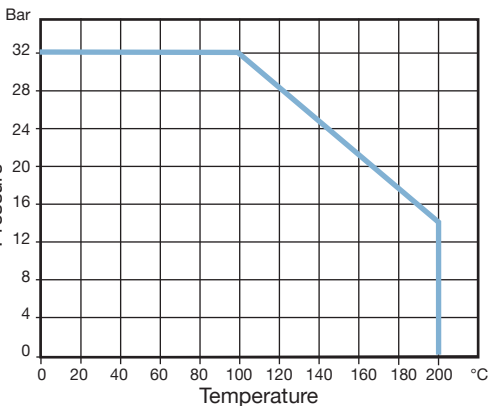

N. Part Name Materials

1 Body	Gunmetal BS EN 1982 CC491K
2 Cap	Brass BS EN 12164 CW614N
3 Screen	Stainless Steel 304
4 O-ring	Viton FKM 75
5 Plugs	Carbon Steel